

IAF GmbH
Berliner Straße 52j
38104 Braunschweig
Germany

Phone: ++49 531 379 88-0
Fax: ++49 531 379 88-30
e-mail: info@iaf-bs.de
www.iaf-bs.de

TMS320C6474 Digital Signal Processor (DSP) **add-on module (rev. 2.1)**

(Data Sheet rev. 2.1 April 2010)

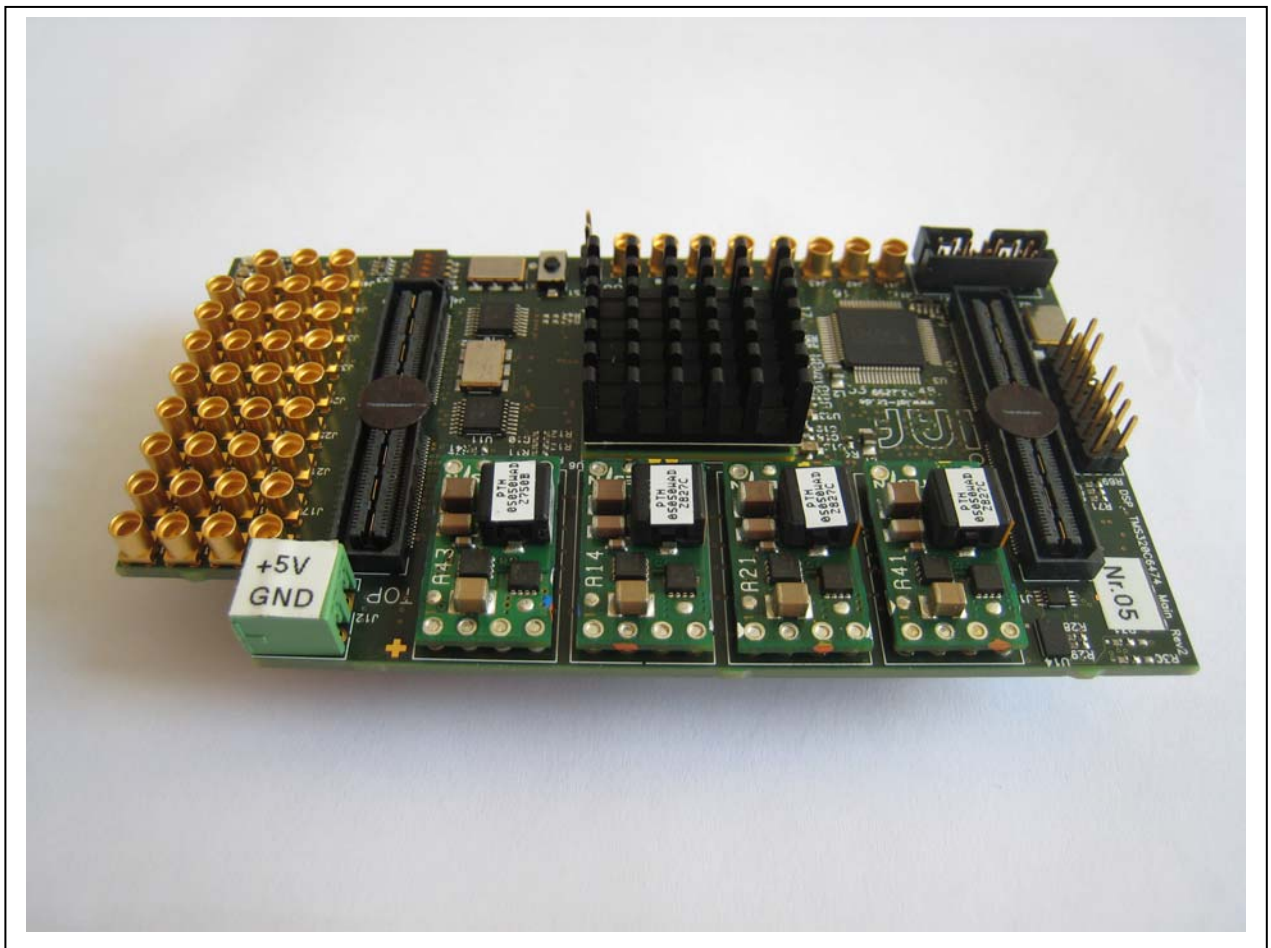

Figure 1: Picture of the TMS320C6474-Main-Board

The DSP-Module, for the FFP-Basic+-Board, consists of two DSP add-on-boards (type Main and type Extension), which are designed for use on a single extension slot of the FFP-Basic+-Board (see Figure 2). The FFP-Basic-Plus-Board, is a Rapid-Prototyping –Board which is built on the Xilinx Virtex V.

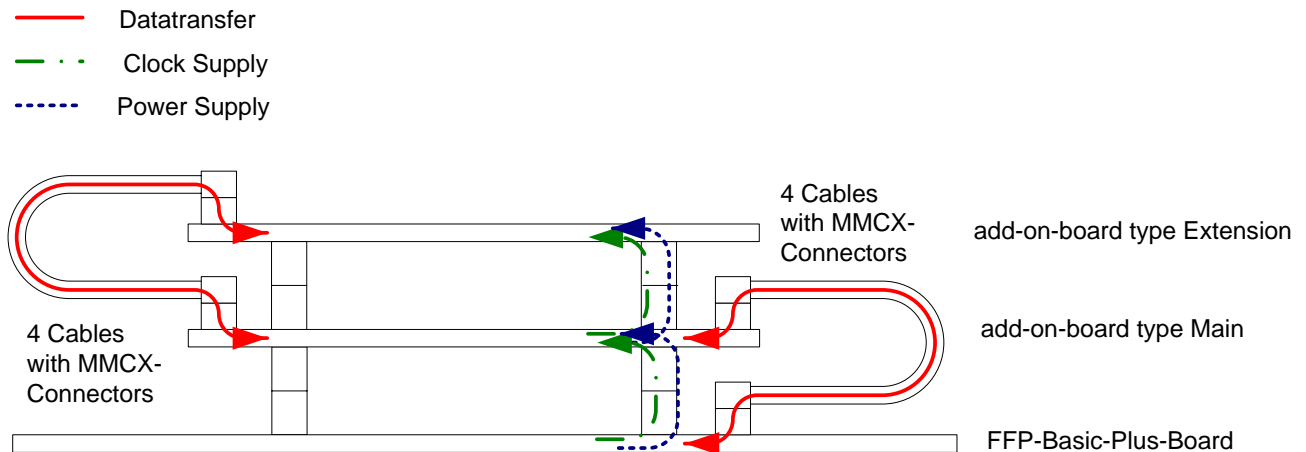

Figure 2: Use of the two DSP-Add-On-Boards on one slot of the FFP-Basic-Board

In combination with an adapter-board the DSP modules are also usable with the FFP-Basic-Board which is built on the Virtex-II-Pro.

It is also possible to use the TMS320C6474 Digital Signal Processor (DSP) add-on module as stand-alone board for communication with other Serial Rapid IO- (SRIO)-Interfaces.

The two boards are a little different.

The Main-Board is the heart of the duo. It contains one DSP TMS320C6474, clock-generation, power supply and conversion.

The Extension-Board can only be used in combination with the Main-Board. There are two TMS320C6474 DSPs integrated. It gets its power and clock from the Main-Board.

The datatransfer between the two boards is realized via MMCX-connector and 4 cables (TXN, TXP, RXN and RXP).

The key features of the two boards are described in the following and shown in Figure 3.

Block Diagramm:

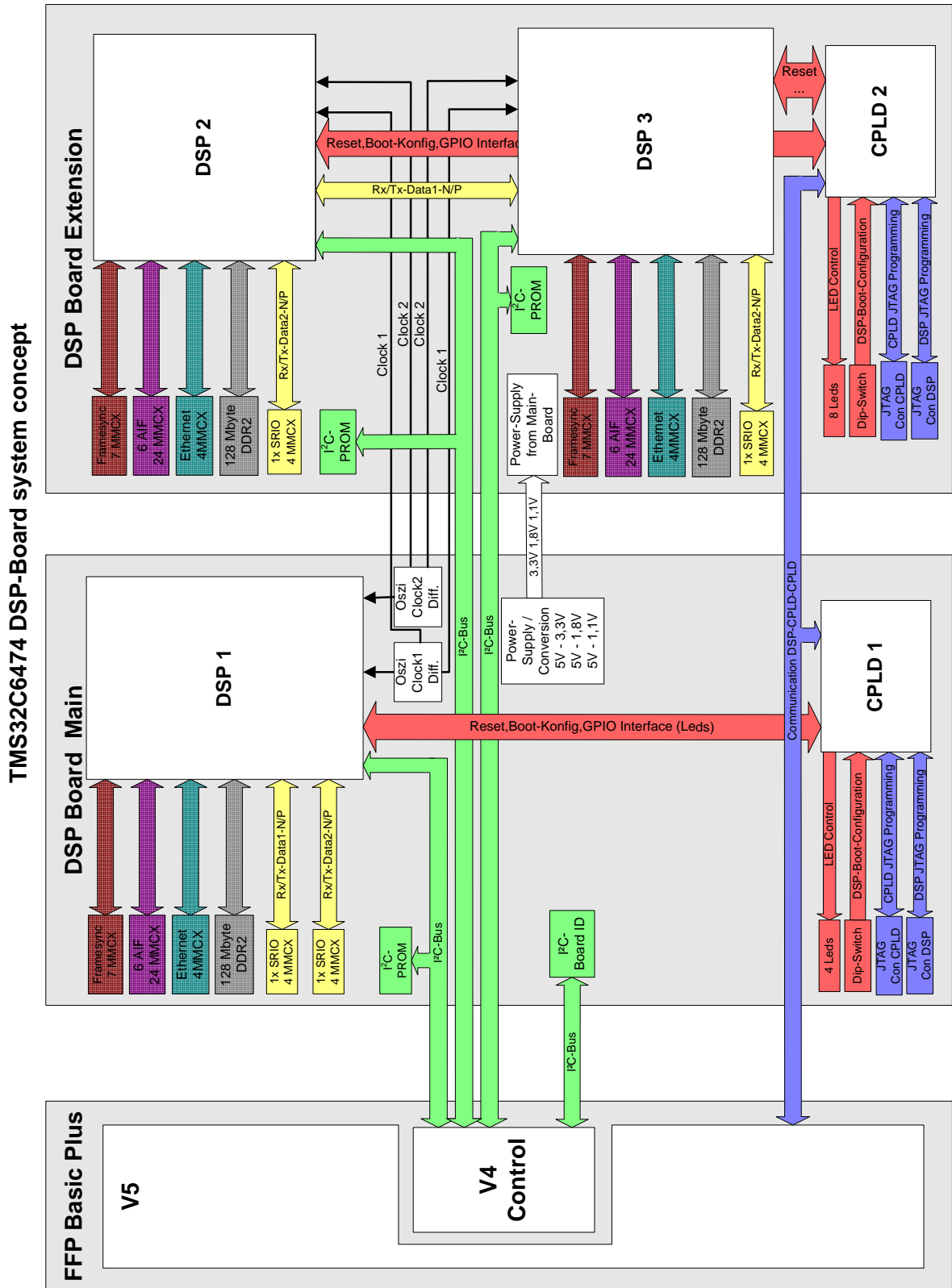

Figure 3: Block Diagram of DSP add-on-Board

The Main-Board has the following key features:

- 1 Texas Instruments DSP TMS320C6474
- JTAG-Connector for using with an external emulator
- 3 NMI (1 for each core of the DSP) controlled via FFP-Basic+-Board
- 1MBit I²C EPROM for DSP programm code, programmable via FFP-Basic+-Board or via DSP
- Xilinx CPLD (Reset-, JTAG, DIP- and LED-Control) with separate JTAG-Connector
- 2 SRIO-Interfaces (2 lanes), each on four MMCX-connectors for communication with FFP-Basic+-Board, Extension-Board or other SRIO-Interfaces
- Antenna Interface (AIF) 6 configurable links (Full Duplex) on MMCX-connectors
- Frame Synchronization Interface on MMCX-connectors
- 128 Mbytes of DDR2 memory
- 1000 Mbps Ethernet MAC (EMAC) on MMCX-connectors
- 4 Dip-Switches with programmable functionality (standard: Dips for DSP-Boot-Configuration)
- 4 On-Board-LEDs controlled via DSP GPIO-Interface (standard) or controlled via CPLD
- Connector with 8 DSP GPIO-Pins for connection of external LEDs or Dip-Switches
- Board-Detection and Board-Identification from FFP-Basic+-Board via I²C
- On-Board clock-generation
- Single-Power-Supply (+5V) via FFP-Basic-Plus-Board or via external power connector (standard), On-Board-Power-Conversion

The Extension-Board has the following key features:

- 2 Texas Instruments TMS320C6474 DSPs
- JTAG-Connector for using with an external emulator
- 6 NMI (1 for each core of the two DSPs) controlled via FFP-Basic+-Board
- 2 MBit I²C EPROM for DSP programm code, one for each DSP, programmable via FFP-Basic+-Board or via DSP
- Xilinx CPLD (Reset-, JTAG, DIP- and LED-Control) with separate JTAG-Connector
- SRIO-Interface 1 (1 lane for each DSP), for communication between the two DSPs on the Extension-Board
- SRIO-Interface 2 (1 lane for each DSP), on four MMCX-connectors for communication with Main-Board, FFP-Basic+-Board or other SRIO-Interfaces
- Antenna Interface (AIF) 6 configurable links (Full Duplex) on MMCX-connectors
- Frame Synchronization Interface on MMCX-connectors
- 128 Mbytes of DDR2 memory for each processor
- 1000 Mbps Ethernet MAC (EMAC) on MMCX-connectors
- 4 Dip-Switches with programmable functionality (standard: Dips for DSP-Configuration)
- 8 LEDs controlled via GPIO-Interface of the DSP (standard) or controlable via CPLD
- Clock- and powersupply via Main-Board

Board -Dimensions:

Figure 4 shows the board dimensions of the TMS320C6474-DSP add-on-boards.

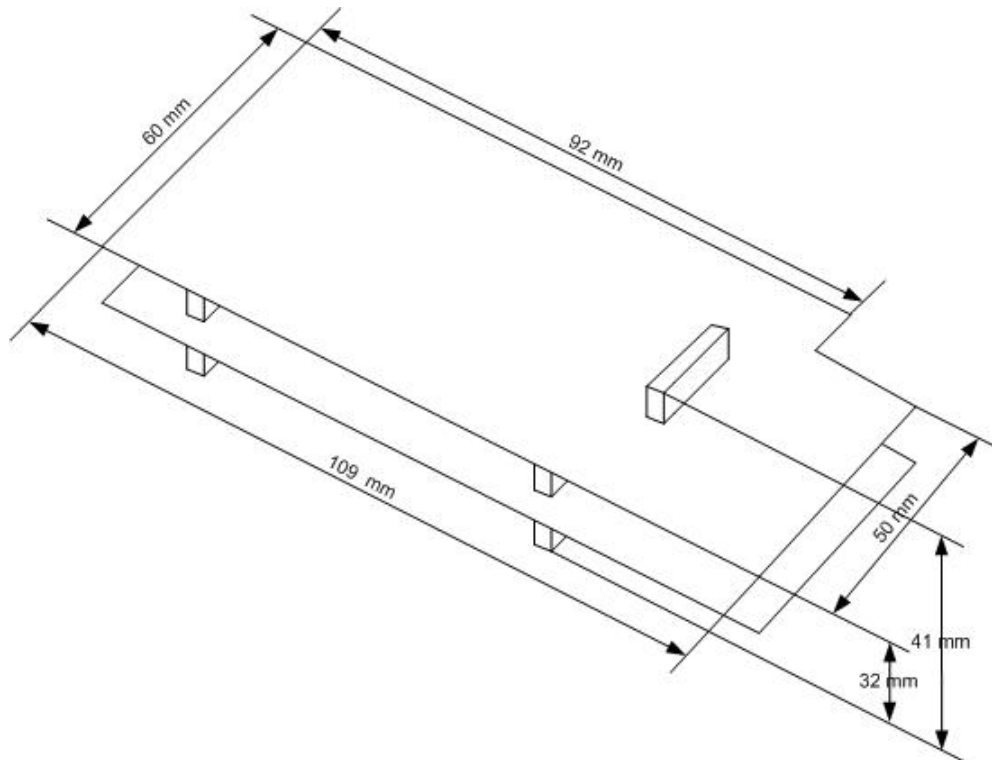

Figure 4: DSP add-on-boards (type Main and Extension) – board dimensions

Programming and debugging

For DSP-programming and –debugging the connector J5 can be used. It is a standard 14 pin TI JTAG connector. Figure 5 shows the connector pinout.

TMS	1	2	TRST-
TDI	3	4	GND
+3,3V	5	6	no pin (key)
TDO	7	8	GND
TCK-RET	9	10	GND
TCK	11	12	GND
EMU0	13	14	EMU1

Figure 5: J5, 14 Pin JTAG connector

If only the main board is used the DSP 1 is in the scan chain for the JTAG interface. The onboard CPLD detects if a second board is connected too. In this case only the JTAG connector on the extension-board can be used and all three DSP are in the scan chain for the JTAG interface.

Integrated Devices

TMS320C6474 DSP from Texas Instruments

XC2C256 CoolRunner-II CPLD from Xilinx

AT24C1024B I²C-Prom from Atmel

MT47H64M16 DDR2 SDRAM 8 Meg x 16 x 8 banks from Micron

Combination possible with the following IAF-Prototyping-Boards

Rapid Prototyping Board Virtex-5 FFP Basic+

More information:

http://www.iaf-bs.de/products/ffp-basic_plus.en.html

Rapid Prototyping Board Virtex-II-Pro FFP Basic

More information:

<http://www.iaf-bs.de/products/ffp-basic.en.html>